



ROYER R-10

Ribbon-Velocity Studio Microphone

The Royer R-10 is a passive mono ribbon microphone designed for critical studio and live performance applications. Its compact size and mounting configuration allows for flexible placement with minimum intrusion. The R-10 exhibits a flat frequency response and a well-balanced soundfield, while at the same time handling sound pressure levels of up to 160 dB @ 1 kHz.

The R-10 incorporates advancements pioneered by Royer Labs, including a multi-layered wind screen and an internally shock-mounted ribbon transducer. The layered wind screen provides superior protection from air blasts and plosives, and also reduces proximity effect so guitar cabinets and acoustic instruments can be close miked with less bass build-up. The R-10's internally shock-mounted ribbon transducer assembly isolates the ribbon element from shocks and vibrations and increases ribbon durability.

The R-10 is a perfect choice for electric guitars, brass instruments and drums, and its figure-8 pattern conveys superb ambience and depth when used for room miking applications. The R-10's smooth frequency response, phase linearity and lack of self-distortion make it ideal for digital recording.

The R-10 incorporates Royer's patented offset-ribbon technology and low mass, 2.5-micron (99.9% pure) aluminum ribbon element. A custom designed impedance-matching transformer minimizes saturation and the open grill configuration minimizes standing waves and associated comb-filtering effects. The transducer's flux-frame design and rare earth Neodymium magnets create a powerful magnetic field which increases sensitivity while reducing stray magnetic radiation.

The R-10's patented offset-ribbon design positions the ribbon element towards the front of the transducer, which allows for the higher SPL handling of the front (logo) side and the option of a brighter response when recording lower SPL sound sources on the back side (3 feet or closer; phase reversed position).

R-10 FEATURES

- High SPL capability for electric guitar, brass and other close miking applications
- Multi-layered wind screen provides superior protection to ribbon element
- Internally shock-mounted ribbon transducer gives increased durability
- Passive design and custom transformer minimize high SPL overload
- Extremely low residual noise
- Ribbon element not affected by heat or humidity
- Absence of high-frequency peaks, "ringing" and phase shifts
- Equal sensitivity from front or back of the element

RECOMMENDED APPLICATIONS

- Close miking in the studio and on live stages
- Electric & acoustic guitars
- Drum overheads, kick drum (see manual for position), room miking
- Percussion instruments
- Brass, horn sections
- Strings - solo & sections
- Acoustic piano
- Vocals



ROYER R-10

Technical Specifications



Acoustic Operating Principle	Electrodynamic pressure gradient
Polar Pattern	Figure-8
Generating Element	2.5-micron aluminum ribbon
Magnets	Rare Earth Neodymium (Grade 52)
Frequency Response	30Hz-15,000Hz +/- 3dB
Sensitivity	-54dBv (re. 1v/pa)
Output Impedance	100 Ohms
Maximum SPL	135dB @ 50 Hz, 160dB @ 1kHz
Recommended Load Impedance	700 Ohms (or greater)
Output Connector	Male XLR 3-pin (Pin 2 Hot)
Dimensions	Length including mounting base: 5 7/8 inches (149 mm) Width 1 3/8 inches (35 mm)
Weight	13 oz (368 grams)
Shipping Weight	Single: 2.5 lbs, Matched Pair: 4 lbs
Accessories	Microphone Holder, Mic Sock, Carrying Case
Microphone	Adjustable Swivel Mount (Black)
Microphone Warranty	Five Years, First re-ribbon free in first year



Matched pairs are available at extra charge

Frequency Response and Polar Pattern

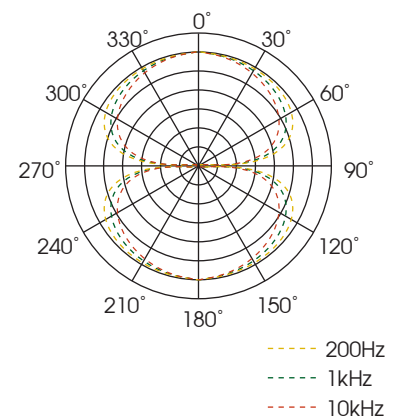
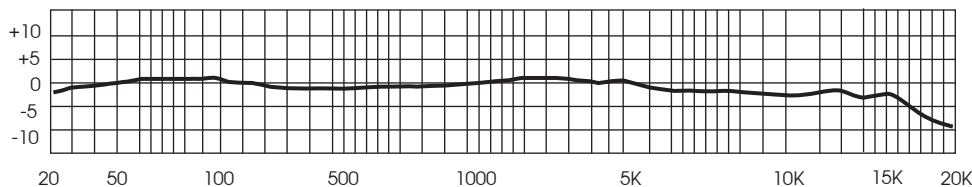

Royer Labs
www.royerlabs.com

2711 Empire Ave, Burbank, CA 91504
Tel. (818) 847-0121 Fax (818) 847-0122

COPYRIGHT ROYER LABS 2017
All specifications subject to
change without notice